

*12 yards  
 shoots 12" high  
 + 6" left.*

31 PRESTIGE PARK CIRCLE, EAST HARTFORD, CONNECTICUT 06108 • (203) 289-9531

**PARTS SCHEMATIC**  
**DERRINGER**  
**.22 CALIBER PISTOLS**

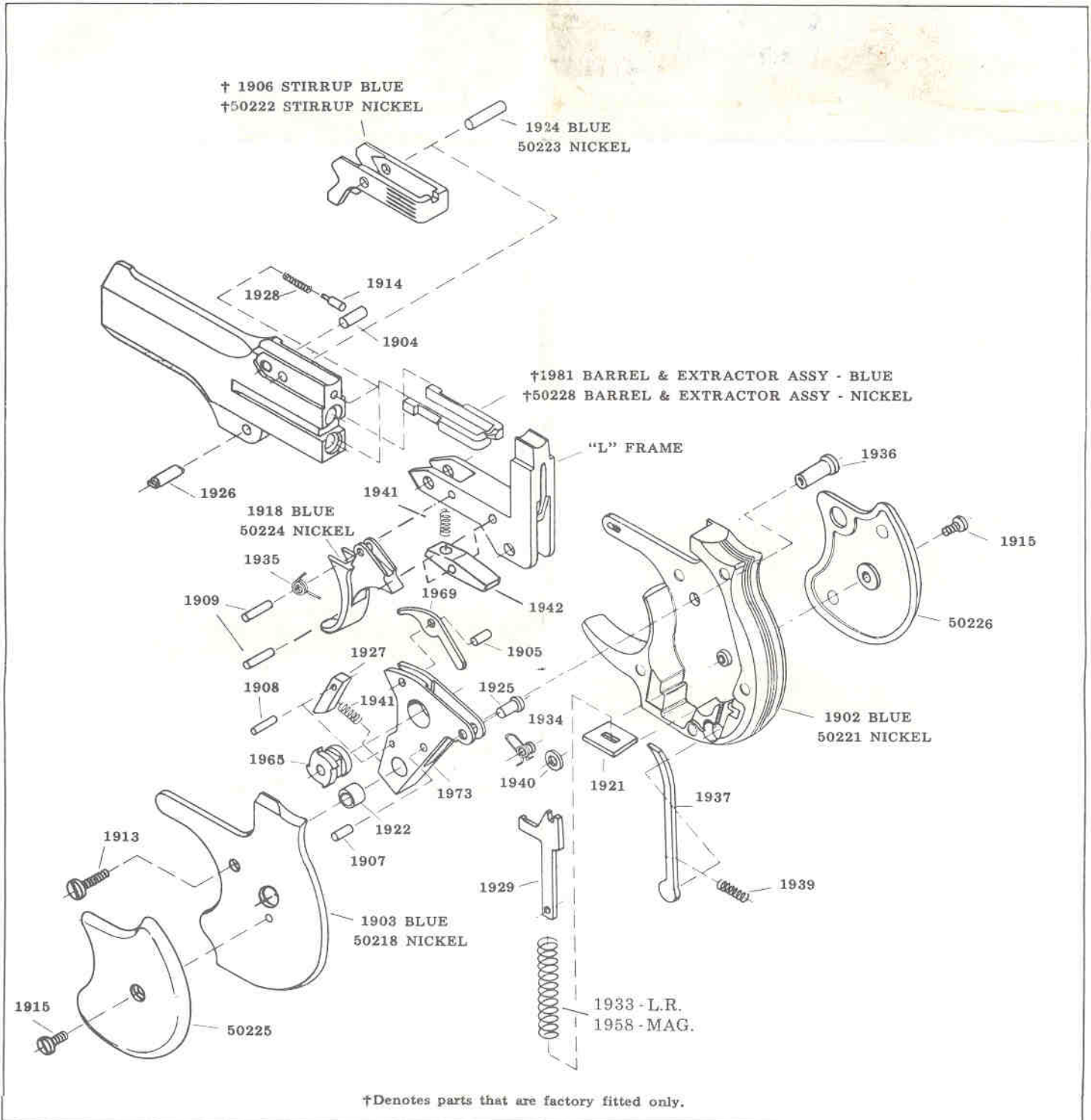

# INSTRUCTIONS FOR OPERATION AND CARE OF YOUR HIGH STANDARD DERRINGER

## Model DM-101 Cal.22 Magnum (.22 W.M.R.F.)

### LOADING:

Your High Standard Derringer is a break-open type two shot pistol with superposed barrels, one barrel is located above the other.

To load the gun, obtain a firm hold on the stirrup with your thumb and forefinger of either hand and lift up until the stirrup disengages the locking lug on the "L" frame. The breech end of the chambers is now easily accessible. **IMPORTANT:** It is imperative to first push the stirrup into a parallel position with the barrels thereby returning the extractor until it is flush with the breech face while the barrels are in the open position before inserting cartridges. A simple pressure on the rear portion of the barrel will snap the stirrup in place and lock the barrels in place.

**CAUTION** — Keep fingers free of trigger at the time of loading the chambers and point the gun in a safe direction, preferably towards the ground.

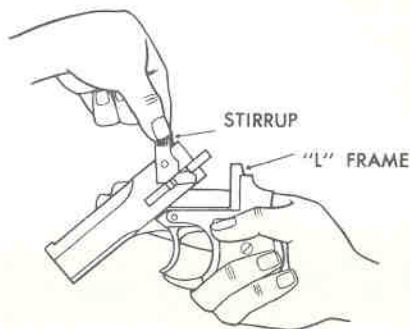

FIGURE 1

### FIRING:

This is a double action pistol in which a mechanism is incorporated that alternates the striker between the lower and upper chambers. To fire the pistol, it is only necessary to apply steady pressure on the trigger until the hammer falls carrying the striker to a cartridge rim. The firing mechanism is non-selective; for example, if the lower barrel had been fired last, the upper barrel will be discharged on the next pull of the trigger and vice-versa.

### UNLOADING OR REMOVAL OF FIRED CARTRIDGE CASES:

In order to remove either live cartridges or fired cases from the barrels, it is only necessary to lift the stirrup in the same manner as described on the loading procedure. Extraction and ejection are automatic.

### CARE AND MAINTENANCE:

1. Before first firing the gun, make certain that the bore is clean and free from any obstruction. If the bore has been filled with grease for extended storage, all grease should be removed before shooting by swabbing out the bores with a .22 caliber bore-cleaning tool. Also remove any excessive accumulation of oil from inside of the barrels.
2. After extensive shooting, cleaning will become necessary. The use of kerosene or any other good cleaning solution is recommended.
3. In cleaning the muzzle, an old toothbrush or similar brush should be used. If mud or foreign matter should enter the bore, a stiff bristle brush or copper wire brush for .22 caliber guns should be used. After brush has removed all mud and foreign matter, the bore should be swabbed with flannel patches attached to a .22 caliber cleaning rod. Patches should be moistened with a good gun oil and the swabbing of the bore should be continued until the patches come out clean.
4. After the face on the "L" frame opposite the breech end of the barrels has been thoroughly cleaned, drop a few drops of light bodied oil through the striker opening into the action.
5. The entire gun should be wiped dry of kerosene or cleaning solution with a clean absorbent cloth and the surfaces should be wiped with a lightly-oiled patch.
6. For best results in rust prevention, only high quality gun lubricants should be used. (See your dealer)
7. Avoid using heavy-bodied oils. No animal or vegetable oils should ever be used on guns.
8. If the gun is used in climates where extreme cold prevails, powdered graphite should be substituted for oil in lubricating the internal mechanism. In moist climates the gun should be cleaned more frequently and preferably stored in a container treated with silicone to prevent rust.

### DRY FIRING:

In dry firing the pistol, it is best to first insert dummy cartridges or fired cases into the chambers. These will prevent damage to the striker and chambers.

**CAUTION:** USE OF CAL. 22 SHORT, LONG OR LONG RIFLE CARTRIDGES IN MODEL DM-101 IS NOT RECOMMENDED.